



MLA

Steel, Alu and Pvc Doors&Windows Machinery



M80

Preview Version - 02/2018

Manual end-milling machine for aluminium and pvc profiles



M80G

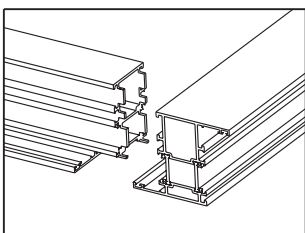
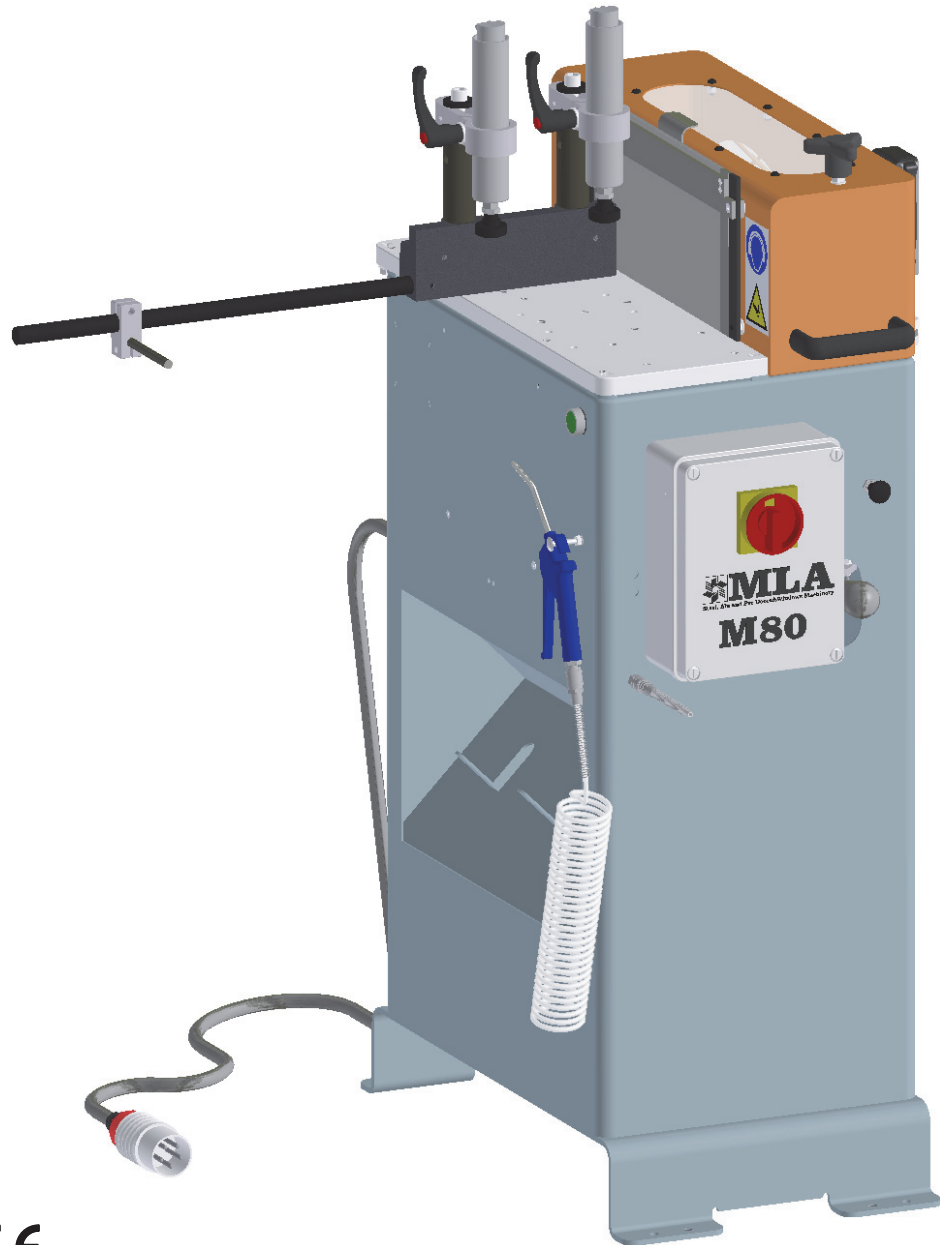

Code 101080

The end-milling machine **M80** is conceived to mill profiles at angles of $45^\circ \pm 135^\circ$.

The profile is blocked by two vertical clamp cylinders.

The clamping system of the mills group is available in two versions:

M80 - standard with pneumatic rapid change;

M80G - with nut.

The profile enters the working box passing through 5mm thick polycarbonate strips. These guarantee the operator's safety by shielding him from possible splintering tool and material, in compliance with the current safety rules.

The viewing window on top of the cover is made of scratch-resistant polycarbonate and ensures a perfect view of the working area throughout the years.

A connection to the aspirator $\varnothing 100\text{mm}$ is placed on the side of the cover.

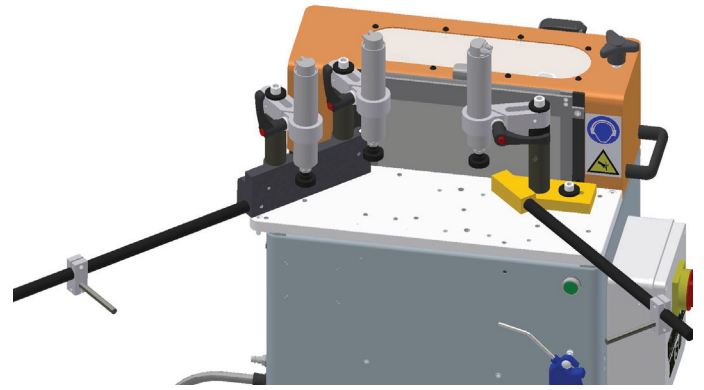
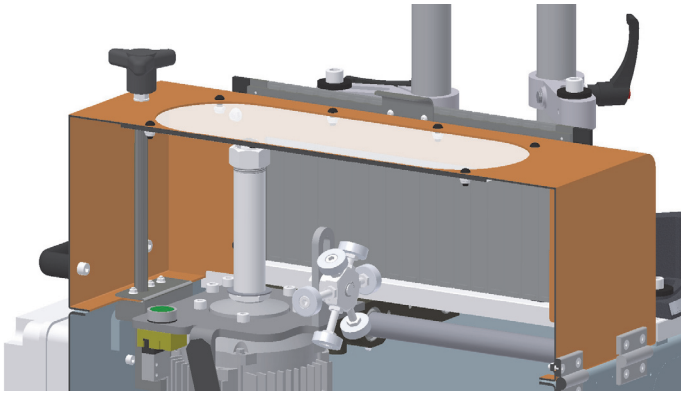

Functioning

Thanks to a vertically adjustable revolver with 6 stops, the profile milling depth can be regulated correctly.

By pushing the switch on the right side of the electric board, the profile is blocked. The vertical clamp cylinders are short-stroked.

By pushing simultaneously the bimanual buttons on the right lever and on the left side of machine, the motor starts rotating and the milling begins.

It's possible to carry out the *finishing milling* during the return stroke, by keeping the two buttons pressed.

When at least one of the bimanual buttons is released, the motor stops; by pulling the switch the profile is unclamped.

It's possible to accomplish the **manual rapid change** of the mills group by turning the time-controlled safety knob and by opening the protection cover.

An optional mist sprayer is available to work aluminium profiles (code 502598).

One optional vertical clamp (code 502599) enables to block the pvc welded profile and to mill the welding seam.

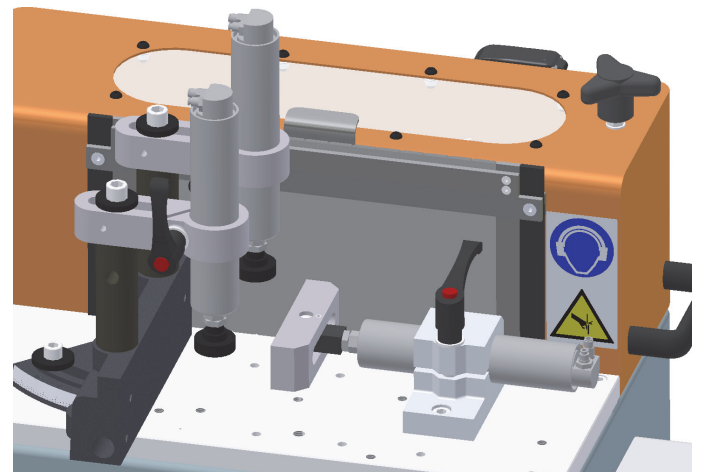

One optional horizontal clamp (code 101080+502321N) enables to block the profile at 45°÷135°.

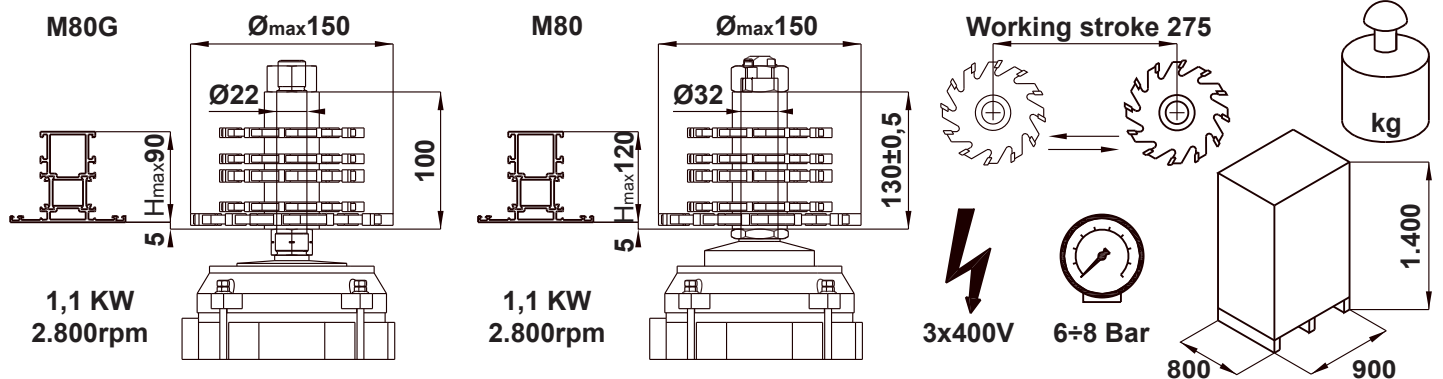

The Company reserves the right to amend and improve its products without notice.