

## Semiautomatic milling drilling machine for pvc profiles

Conceived to carry out the slot and the triple drilling for the window handle insertion on pvc profiles with steel stiffener (drilling only).

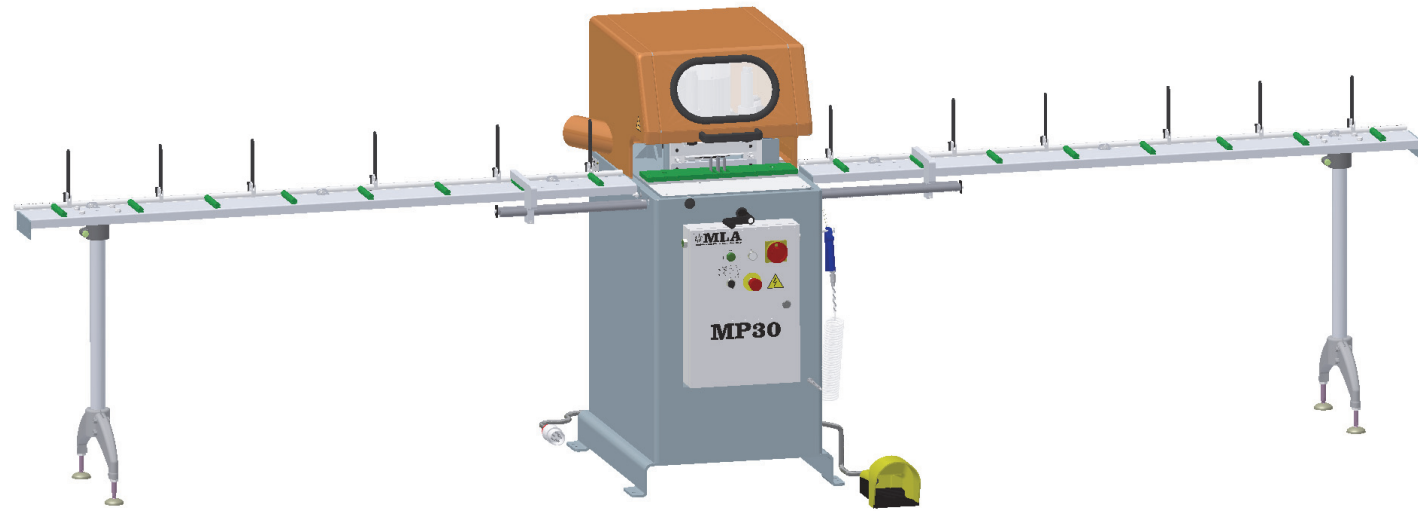

Code 105302S = 105302 + 502548 (Symmetric centring device).  
+ code 502549 (Lateral supports l=2m with 6+6 stops on millimetre rod).

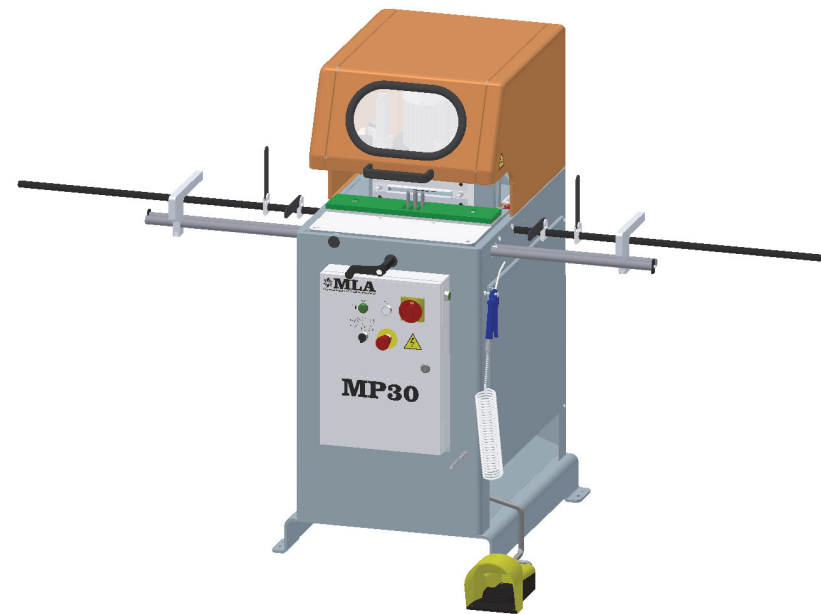

Code 105302S = 105302 + 502548 (Symmetric centring device).  
+ code 502411 (2+2 lateral stops on rod l=1m).



CE

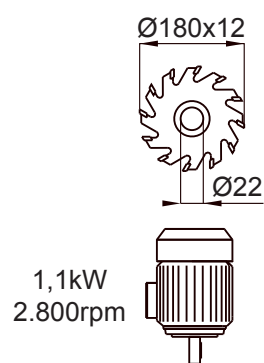

1,1kW  
2.800rpm

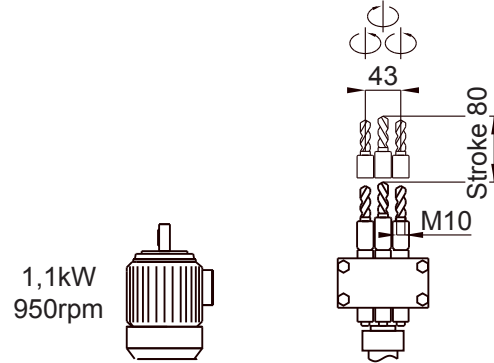

1,1kW  
950rpm



3x400V



6+8bar

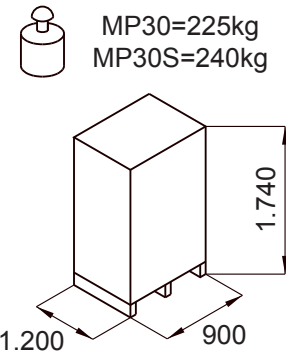

MP30=225kg  
MP30S=240kg

The comfortable front opening enables an easy positioning of the profile, which is visible through the scratch-resistant polycarbonate window: this solution allows the operator to check the working operation in full safety.

News: starting from this version of MP30 it will be possible to use both symmetric centring device and profile lateral supports at the same time.

The Company reserves the right to amend and improve its products without notice.

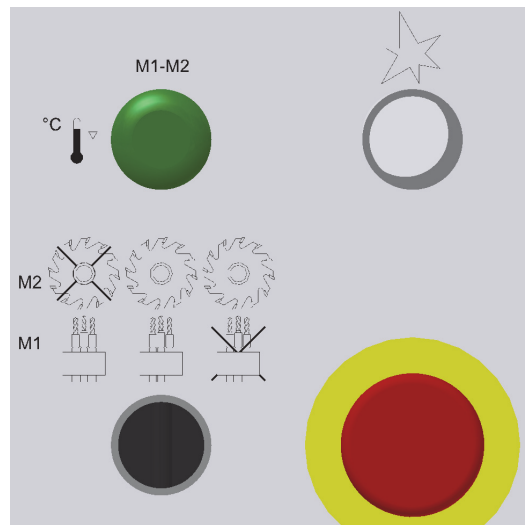

### Functioning

The profile clamping takes place by pressing the pedal activating the short stroke clamp cylinders.

The working cycle is set in motion by pushing the buttons on the right and left side of the electric board simultaneously (certified bimanual device EN574-3A).

At the end of the working cycle, the profile is unclamped automatically.

It is possible to select the complete working cycle or the milling or drilling cycle only.

Each motor is equipped with a thermic feeler that stops the feeding in case of overheating, protecting the integrity of the motor itself.

The milling depth can be selected by using 6 stops displayed as a star on the revolver.

The horizontal milling motor is equipped with servo brakes that guarantee the tool immediate stoppage.

The drilling unit is equipped with a oil-pneumatic drive.

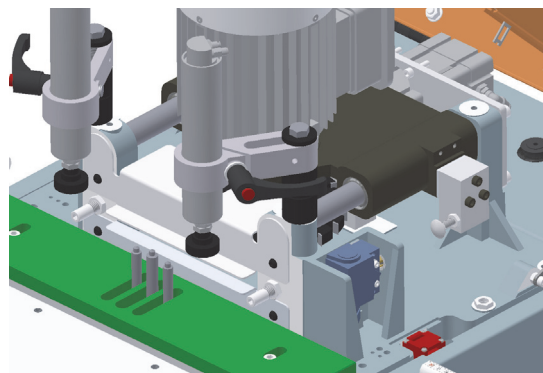

Lateral supports l=1m with 6+6 stops on millimetre rod code 502491

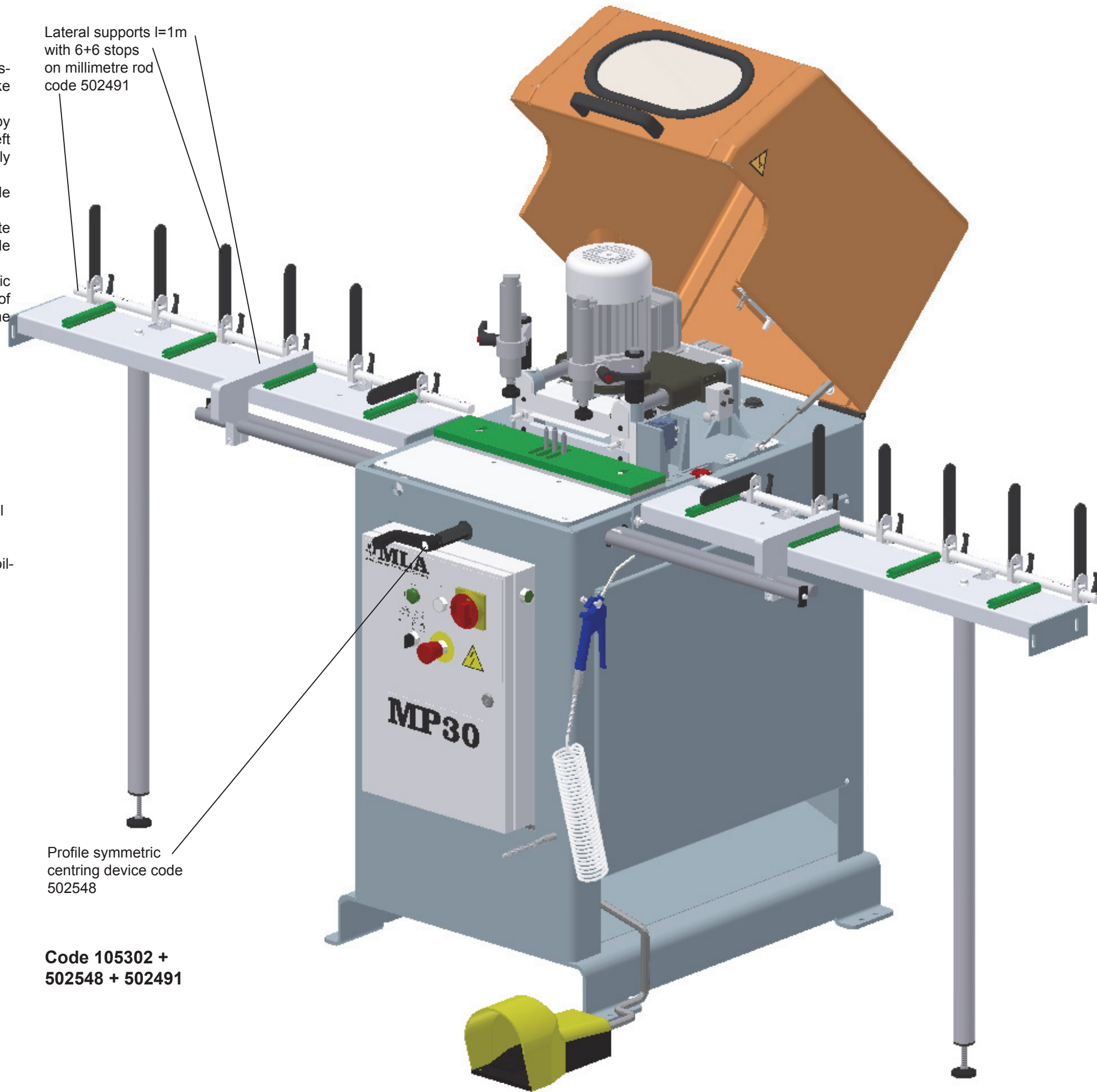

Profile symmetric centring device code 502548

**Code 105302 + 502548 + 502491**