

**Classic Magic**  
Twin-head cutting-off machine

Control 01

Tilting of the moving cutting heads 02

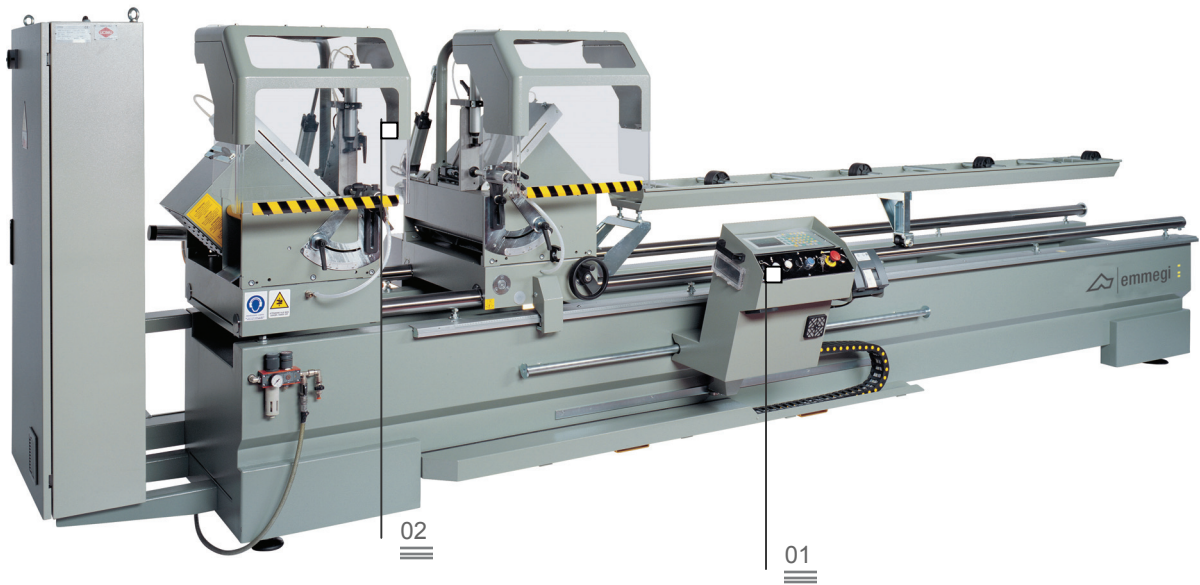

02

01

The Emmegi twin-head cutting-off machines boast of exceptional performance characteristics, including ruggedness and reliability. This machine is ideal for cutting aluminium and PVC bars in various thicknesses and at different angles. Latest generation machines which can make a considerable contribution to the production cycle thanks to their high standard of accuracy and user-friendliness. Classic Magic is an electronic twin-head cutting-off machine with automatic traversing of the moving cutting head. The machine can be provided with an industrial label printer to enable profile identification and association with relative job.

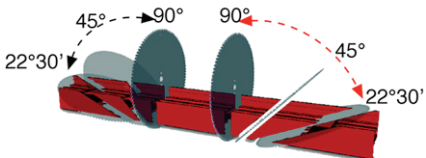

Digital readout for intermediate angles 03

Label printer 04

Intermediate support 05



# Classic Magic

Twin-head cutting-off machine

## 01 Control

The user-friendly control panel installed on the various models, runs on bearings and allows correct positioning of the moving cutting heads according to cutting specifications. The work cycle is optimized through creation of the cutting lists thus reducing scrap as well as workpiece loading/unloading times.

## 02 Tilting of the moving cutting heads

Rotation of the heads about the horizontal axis is powered by pneumatic cylinders. External angles from 90° to 45° can be obtained from machines fitted with 450 mm diameter blades. Using 500 mm blades, it is possible to obtain external angles from 90° to 22°30'. Intermediate angles can be obtained by using the appropriate manually adjustable stop. The moving cutting heads are fully guarded in the work zone and lowering of these guards is pneumatic.

## 03 Digital readout for intermediate angles

When there is pneumatic tilting of the moving cutting heads, the intermediate angle readout allows exact identification of the tilting of the cutting head, thereby ensuring accuracy of the cut profiles. This device, which is specially useful in making cuts at intermediate angles, allows the operator to identify the required angular setting quickly and accurately.

## 04 Label printer

The industrial label printer allows identification of each cut profile with the profile I.D. data originating from the cutting list. In addition, the printing of bar codes permits easy identification of the actual profile, which is particularly useful for subsequent machining phases on the machining centers or on assisted assembly lines.

## 05 Intermediate support

The pneumatic intermediate support proves highly useful when cutting light profiles with considerable lengths. In such case the pneumatic support automatically seeks to create the ideal condition to support the profile. This accessory is available for all lengths, but it is especially recommended on machines with cutting capacity of 5 and 6 metres.

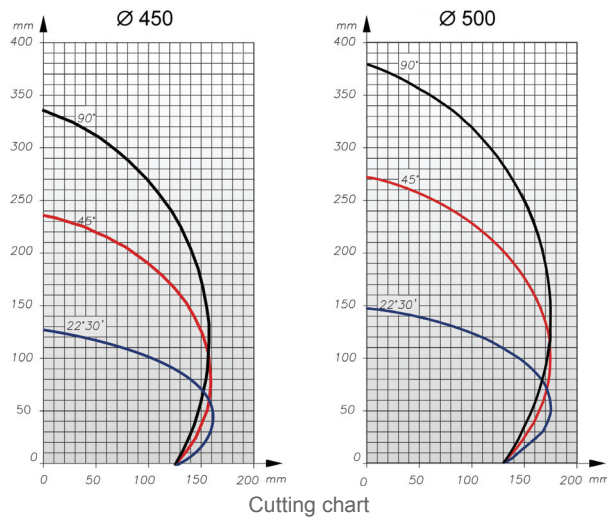

### CONTROL CHARACTERISTICS

- Back-lit LCD display
- Provision for connection to industrial label printer
- USB port
- Execution of single cuts
- Memorization of 99 profile compensations with automatic calculation of the size for angle cuts
- Memorization of 20 cutting lists (each with 50 lines) via keyboard
- Memorization of 10 cutting lists (each with 100 lines) via cable from external PC through RS232 board

### MACHINE CHARACTERISTICS

- Measurement of moving cutting head position via direct measuring system with magnetic tape
- 2 carbide-tipped blades
- Full guard for cutting zone, pneumatically operated
- Pair of horizontal pneumatic clamps with "low pressure" device
- Profile support roller conveyor
- Lubrication system, spray-mist lubrication with oil and water emulsion or minimum quantity oil lubrication (depending on version)
- Cutting angles with blade Ø 450 and 500 mm from 22°30' (external) to 90°
- Manual profile support
- Provision for automatic start of swarf exhauster MG4
- Pair of standard counterblocks
- Metric scale
- Cutting capacity 4/5/6 m depending on model
- Blade motor power rating (kW)

2.2